

W294

Manual, plastic vertical uncapper - module, 1/2 Dadant

USER MANUAL



Przedsiębiorstwo Pszczelarskie Lysoń Sp.
z o.o. Ul. Pszczela 2, Klecza Dolna, 34-
124 Klecza Górna NIP: 551-260-51-86

tel. +48 33 857-99-40, +48 33 875-93-24, + 48 33 844-75-21,

www.lyson.com.pl , e-mail: lyson@lyson.com.pl

SHORT DESCRIPTION:

The machine for honeycomb cutting and board printing is a manual device, which facilitates the beekeeper's work during the course of the primary yield of honey. It is compatible with different standards for shop honeycombs, featuring height up to 160 mm. It operates, while applying the principle of the printing-out fork, as it takes away by 3 mm from both sides of the surface layer below the level of the frame.

NOTE:

The machine doesn't require electricity or steam. The machine operates at temperature above 30 degrees Celsius with honeycombs, at which the process of crystallization has not started yet. The honeycombs should have been tempered at 30 degrees for at least 12 hours.

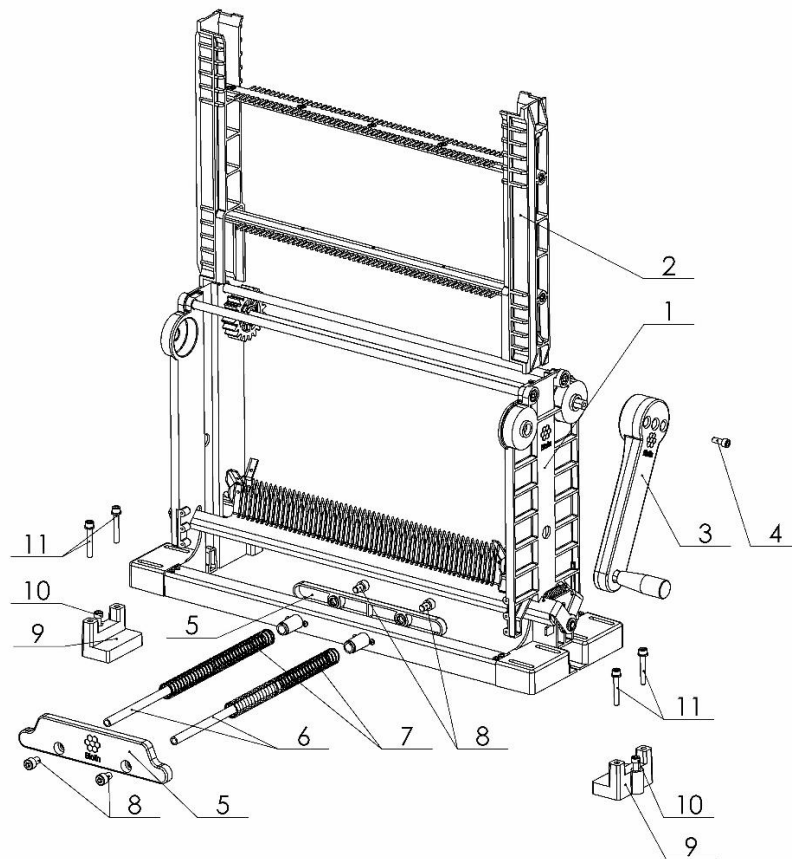

MONTAGE:

In the box you would find a body (1), guides (2), handle (3), pusher (5; 6; 7), 2 fixing elements (9) and fasteners (4; 8; 10; 11).

After taking the body out of the box, you have to montage the handle (3) on left or the right side using bolt №4 (M6x16). You will find it in the plastic bag.

To montage the pusher, first you would have to dismantle piece №5 via two fasteners №8 (M8x12), place it as shown in the picture, then montage piece №5 again.

After that you have to fix the machine onto the edge of the board of the honey tub. Bolts №11 (M6x50) are used to fixate the machine depending on the different boards of the honey tubs and they can regulate in height and width. Bolt №10 (M6x16) is used to secure that the machine stays still and doesn't move around. Its head has to be on the same level as the board of the tub.

Then you are ready to use it. Depending on the width of the honeycomb (25mm or 36mm) the guides can be rotated.

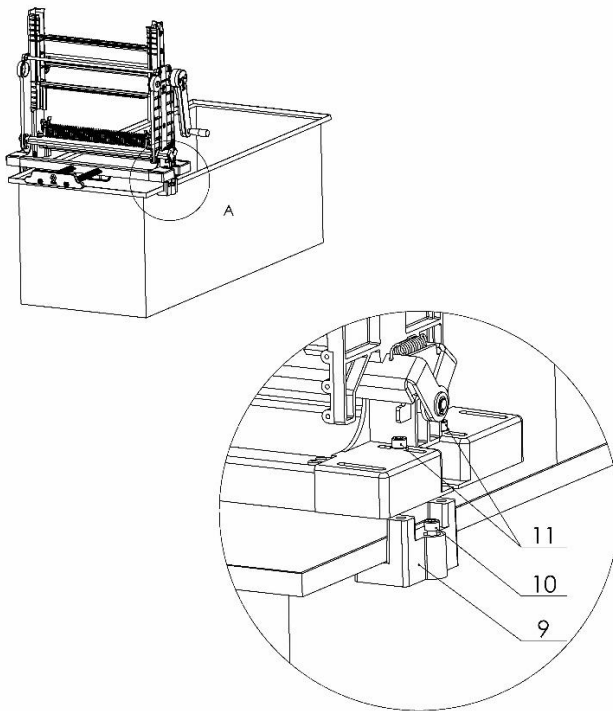

Use:

The honeycomb is placed between the knives and gets fixed with the guides. By rotating the handle, the honeycomb is cut down and falls onto the rails of the honey tub. By means of the pusher the honeycomb is moved forward.

Materials:

The plastic parts are made of polyamide, being fit for nutritional purposes. The metal parts are manufactured from inox.