

Instructions manual

MINIMA LINE

Uncapping machine with closed circuit heating system or steam generator



LYSON

Przedsiębiorstwo Pszczelarskie Łyson

Spółka z o.o.

34-124 Klecza Górna, st.Pszczela 2, Poland

www.lyson.eu, e-mail; lyson@lyson.com.pl

Tel. +48 33/875-99-40, +48 33/870-64-02

The manual covers following devices (codes):

Closed circuit heating system versions: **W2092_Z, W20921_Z**

Steam generator versions: **W2092_W, W20921_W**

Table of contents

1. General safety instructions
 - 1.1. Intended use
 - 1.2. Electrical safety
 - 1.3. Operation safety
2. Instructions for use
 - 2.1. General instructions – preparation for use
 - 2.2. Operation instructions
3. Product description
 - 3.1. Product design
 - 3.2. Technical specifications
4. Storage
5. Maintenance and cleaning
6. Waste disposal and environmental protection
7. Warranty



Product images are for illustrative purposes only and may sometimes differ from the actual appearance of the item. However, this does not change their basic properties.

1. General safety instructions

Before first use read the manual carefully and follow the instructions contained therein. The manufacturer is not liable for damage caused by equipment used inappropriately or by incorrect handling.

1.1. Intended use

The uncapping machine is a device which allows to mechanically prepare sealed off bee combs for the honey extractions process.

1.2. Electrical safety

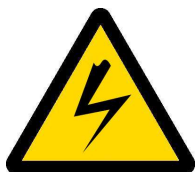

1. The electrical supply system must be fitted with a residual-current circuit breaker with rated tripping current not higher than 30mA. Performance of the circuit breaker should be checked periodically.
 2. Periodically check the condition of the power cord. Replace the power cord if damaged. Replacing the power cord can only be performed by the manufacturer or by qualified personnel. Do not use the device if the power cord is damaged!
 3. Make sure that the main switch (8) is in „0” position before plugging the unit in.
 4. Connect the device to a socket with voltage specified on the rating plate of the product.
 5. Carefully connect the plug into the mains socket. Make sure your hands and the floor surface in the room are dry!
 6. Do not move the device during operation.
 7. Protect the motor and the control unit against moisture (also during storage).
 8. Do not pull the power cord.
- Keep the power cord away from heat sources and sharp edges to ensure its good condition.



1.3. Operation safety

1. The device is not intended for use by persons (including children) with limited physical, sensory or mental abilities, or by inexperienced users, unless under supervision or with instructions given by an accountable party.
2. This device is not a toy, and shouldn't be used as one. Children should not to play with it.
3. In the event of damage to the device, to avoid any health and safety risks, repairs should be carried out only by qualified personnel.

4. Never carry out any maintenance or repairs during operation or if the device is plugged in!

5. All covers must be firmly attached to the device during operation

6. In case of any danger, use the safety switch immediately. The device can be restarted after the hazard has been eliminated.

7. For indoor use only. The device is not suitable for outdoor use.

8. Do not use or store the device at the ambient temperature below freezing. If the device has been moved from a cold room to a room with a higher temperature, before switching on wait until it reaches room temperature.



Never carry out any repairs during operation



Do not remove covers during operation

2. Instructions for use

2.1 General instructions – preparation for use

1. Set the device up in a designated, clean, dry and well lit room.
2. Keep a free space around the device for better handling.
3. Once the device is set up, lock the caster wheels to prevent the device from moving.
4. Provide easy access to the power source.
5. Closely follow the instructions of use.

2.2 Operation instructions

1. The uncapping machine is a device which allows to mechanically prepare sealed off bee combs for the honey extractions process.
2. The device has to be cleaned before the first use and after finishing work according to the instructions in the "Cleaning and Maintenance" section.
3. Before start:
 - Fill up the heating system's tank (2) with distilled water via port (3), the same procedure applies to the steam generator (22)
 - Set the water circulation pump switch (7) to position "1", plug in to the power supply socket and switch the heater on (5) or plug the steam generator's power cord into the socket (22).
 - Wait until the water in the water generator and the cutting blades (14) reach the temperature set on the thermostat (1). The water in the steam generator will start to boil and turn into steam.
 - Plug in the power cord of the uncapping

machine (13) into the power socket and on the control box (9) switch (8) to RIGHT or LEFT to engage the frame feeder (11) and uncapping chains (14).

- Place the previously prepared frames on a working feeding chain (11), pay close attention to their correct positioning (parallel to each other and perpendicular to the chains). Incorrect arrangement of the frames may cause damage or breakage.
- With the RIGHT-LEFT switch (8), allows to control the process of feeding of the frames or to reverse the direction in case they get stuck on the feeder chains.
- The depth of uncapping and spacing between uncapping knives (14) can be adjusted with two dedicated levers (15) and (16)
- Adjust knives in necessary after uncapping some frames if their performance turns out to be unsatisfactory
- The frames, after being uncapped, are deposited one after another on the table rails (17).
- Put the uncapped frames into the honey extractor.
- Cappings created in the process fall down on perforated screens (19) located above the bottom of the table.
- The dripping honey falls to the bottom of the table and can be drained through the drain valve (18).
- Place a honey container under the open drain valve.



Do not adjust any work parameters while the machine is running.

3. Product description

The mechanical uncapping machine together with the hot water closed circuit system / steam generator are designed to work with 230V power supply. The blades of the machine are heated up by hot water or steam produced in the generator. The pump continuously circulates hot water through the knife heating system. Chain feeder allows for smooth and continuous supply of frames. The adjustable knife settings allow to optimise operation of the device and properly uncap the frame surface.

3.1. Product design

- 1-heater with a thermostat
- 2-water heating unit
- 3-tank cap with a bleed nipple
- 4-power cord
- 5-heater's power switch
- 6-heater's controller
- 7-circulation pump
- 8-Left-Right switch
- 9-uncapping machine controller
- 10-safety switch
- 11-frame feeder rails
- 12-drive motor
- 13-power cord 230V
- 14-uncapping knives
- 15-locking lever
- 16-adjustment lever
- 17-uncapping table with shaped bottom
- 18-drain valve
- 19-perforated sieve
- 20-hot water/steam supply hose
- 21-cold water/steam return hose
- 22-steam generator
- 23-water heater unit

Fig.1



Fig.2

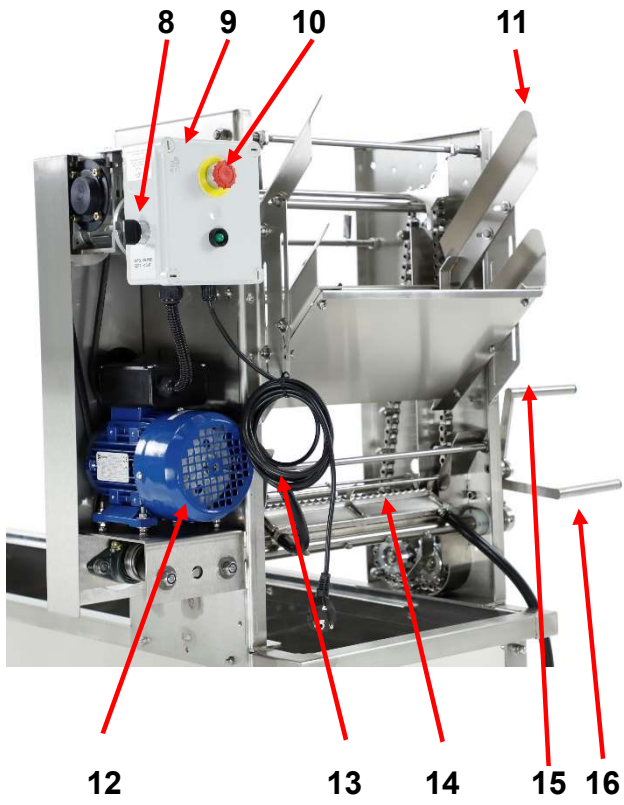

Fig.4



Fig.3

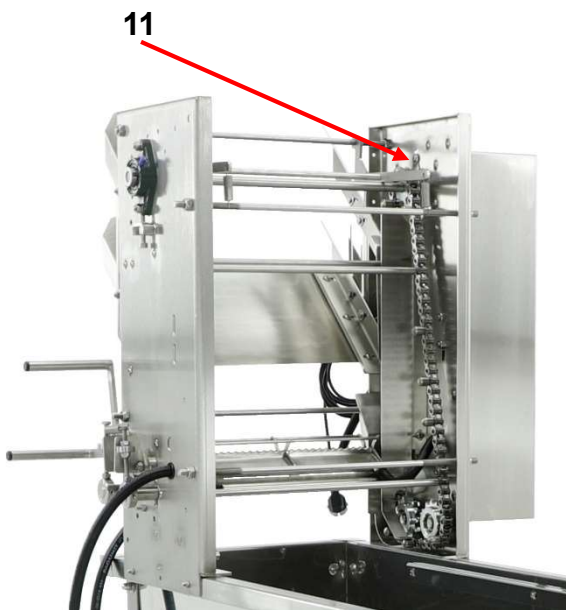
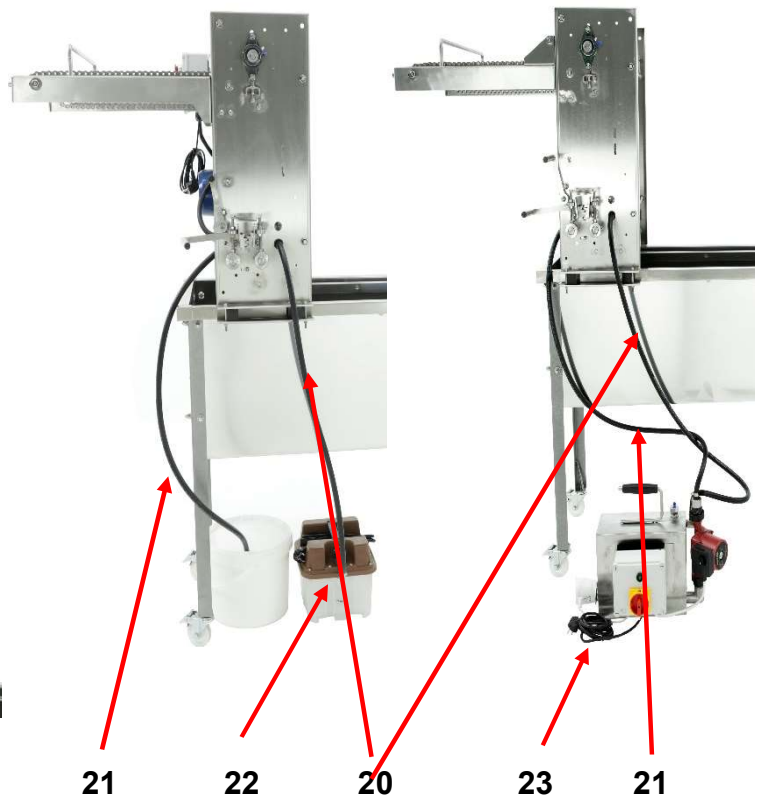

Fig.5



3.2 Technical specifications

Frame

Made of 3 mm wall thickness acid resistant stainless steel profiles

Drive system

230V, 0,25kW and 1400 rpm motor. Uncapping speed approx 6 frames a minute

Heated knives:

Water heated version

The blades are heated by hot water circulating in the closed heating system supplied by a water heater unit. The heater is powered with 230V and is equipped with a built-in thermostat with adjustment range of 30÷110°C.

Heater's power consumption – 2kW.

The 8.5 L tank should be filled with 6L of distilled water.

Circulation pump power rating – 72W.

Knife warm-up time – about 20 minutes.

Steam heated version

The blades are heated by a 2kW 230V steam.

The generator has a 4L tank.

Knife warm-up time – about 15 minutes.

Uncapping table

The machine's table with a conical shaped bottom is made of 0.8 mm thick acid resistant stainless steel.

The legs are powder coated.

Two stainless steel sieves covering the whole length of the bottom.

Drain valve

Stainless 6/4" flap design.

Dimensions:

- uncapper

- height -700mm.
- width -900mm.
- length -800mm.

- table

- height -860mm.
- width -555mm.
- Length -1560mm.

- total weight – 87 kg

- uncapper - 54 kg

- water heating system – 8 kg

- steam generator – 2,5 kg

- chain frame feeder's height above ground - 1350 mm.

- drain valve's height from the ground – 280 mm.

4. Storage

Clean and dry the unit thoroughly after use.

If the device has been moved from a cold room to a room with a higher temperature, before switching on wait until it reaches the ambient temperature and all condensation water evaporates.

Store the device in a dry and frost-free room.

Do not use the device when the ambient temperature is below 5°C.

An additional technical check should be carried out periodically, and if any defects are found, please contact the manufacturer.

5. Cleaning and maintenance



Unplug the device from the power supply outlet before performing any maintenance!

Before first use and after finishing work the equipment must be thoroughly cleaned and dried. While cleaning ensure the safety of all electrical components like motors and controller panels (for the time of washing cover them with waterproof fabric or plastic film).

No parts of the device require chemical conservation including the feeder chain.

An additional technical check should be carried out before the start of the pollen harvesting season, and if any defects are found, please contact the manufacturer.

IMPORTANT!

If you notice any build-up of limescale on the heater of the steam generator or closed circuit, purchase and apply a suitable descaling agent. The limescale deposits may cause the water to reach boiling temperature longer and may cause the heater failure. After removing the limescale, rinse the system several times. Remove any remaining limescale residue from the generator as it may cause part's corrosion.

6. Waste disposal and environmental protection

The used product must be disposed in accordance with the local regulations. Return the device to a collection point from where it can be submitted for environmentally compatible recycling.

The consumer has the right to return used equipment directly to the manufacturer's distribution network, free of charge, while replacing it with a new unit as long as the used device is of the same kind and same application as the newly purchased device.

7. Warranty

The product purchased from the Lyson Company is covered by a manufacturer's warranty. The warranty period is 24 months from the date of purchase.

All purchased products come with receipts or VAT invoices.

Warranty details at:

www.lyson.com.pl

