

**USER MANUAL OF
TANGENTIAL HONEY EXTRACTORS
FI 500-600 MM
AND RADIAL HONEY EXTRACTORS FI 600
MM type Premium Line**



LYSON

Przedsiębiorstwo Pszczelarskie Łyson

Spółka z o.o.

34-124 Klecza Górna, st.Pszczela 2, Poland

www.lyson.eu, e-mail; lyson@lyson.com.pl

Tel. +48 33/875-99-40, +48 33/870-64-02

This manual is intended for the following extractors:

PREMIUM LINE tangential honey extractors:

w2012P, W20120P, W2013P, W20130P

PREMIUM LINE radial honey extractors:

W202P, W203P, W2002P

User manual

1. General safety rules of honey extractor use
 - 1.1. Rules for the use
 - 1.2. Electrical safety
 - 1.3. Safety in use
2. Instructions for honey extractor use
 - 2.1. General rules for the preparation of honey extractor to work
 - 2.2. Rules for the use
3. Honey extractor scheme (diagram)
 - 3.1. PREMIUM LINE electric extractors scheme
 - 3.2. PREMIUM LINE electric+manual extractors scheme
4. Characteristics of PREMIUM LINE honey extractors
 - 4.1. Tangential and radial honey extractors
 - 4.2. Technical parameters of tangential and radial honey extractors
5. User Manual of controller in PREMIUM LINE tangential and radial honey extractors FI 500-600
 - 5.1. Advanced automatic controller SDD-03
 - 5.2. User manual of controller in PREMIUM LINE honey extractors
 - 5.3. Configuration of controller
 - 5.4. List and description of parameters
 - 5.5. List and description of errors
6. Storage of honey extractors
7. Maintenance and cleaning honey extractor
 - 7.1 Disassembly of the basket in PREMIUM LINE honey extractors
8. Disposal
9. Warranty

1. General safety rules of honey extractor use



Before using the device please read the instructions for use and follow the instructions contained in the manual. The manufacturer is not responsible for any damage caused by the use of the device contrary to its intended purpose or inappropriate handling.

1.1. Rules for the use

1. The honey extractor is designed to centrifugation of honey from the frames.
2. Before centrifugation honey extractor must be washed thoroughly with hot water with a small amount of preparations permitted to washing devices intended to come into contact with food, or using a pressure washer, remembering to protect electronic components and bearings against getting wet!!!
3. After washing, rinse thoroughly.



1.2. Electrical safety

1. Electrical wiring of distribution system must be equipped with RCCB /residual (current) circuit breaker with currently rated voltage of tripping and not more than 30mA. Periodically, you should check the operation of the overcurrent circuit breaker.
2. If the fixed power cord or connection cord becomes damaged and it needs to be replaced, it this operation should be performed on the guarantor or by a specialized repair shop or by a qualified person in order to avoid a hazard. Do not use a honey extractor, if power cord or connection cord is damaged.
3. Before switching on the device to power supply, make sure that the control is switched off. Circuit-breaker on the control panel should be in a "0" position.
4. Make sure that the nominal voltage of honey extractor and of power source are compatible.
5. When connecting to power supply you should be careful. Hands must be dry! The ground (base) on which stands the centrifuge should be dry!
6. When starting the honey extractor, the "Emergency STOP" push-button should remain off (it should be turned so that it jumped out). Pressing the "Emergency STOP" button, allows you to immediately stop of centrifuge operation.
7. Cover (lid) of honey extractor during centrifugation must be closed! It is forbidden to open the lid of honey extractor during centrifugation.
8. Do not move the honey extractor during centrifugation.
9. You must protect the motor and controller against moisture; (also during storage)
10. It is forbidden to pull on the power cord. Keep the power cord away from sources of heat, sharp edges and take care of its good technical condition.

1.3. Safety in use

1. This appliance is not intended for use by persons (including children) with reduced physical, sensory or mental capabilities or lack of experience and knowledge unless they have been given supervision or instruction concerning use of the appliance by a person responsible for their safety. Children should be supervised to ensure that they do not play with the honey extractor.
2. In the event of damage to the honey extractor, in order to avoid the hazard, the repair can only perform a specialized repair shop or by a qualified person.
3. It is prohibited to carry out any maintenance work when the appliance is operating.
4. All guards must be permanently attached to the honey extractor when the appliance is operating
5. In the event of any hazard, you should immediately use the safety switch. Restart the honey extractor may occur after the elimination of hazard.
6. These devices are not designed for use outdoors, may be operated only within the premises.
7. Do not turn on and store the device at a temperature below 0° C. You should not turn on the honey extractor when the ambient temperature is lower than 5°C. Before starting the honey extractor, in the case where it was moved from the room of a lower temperature to room with a higher temperature, you should wait until it reaches the ambient temperature.



Ban on repairing the device which is in motion



Ban on removing guards when operating the device

2. INSTRUCTIONS FOR HONEY EXTRACTOR USE

2.1. General rules for the preparation of honey extractor to work

1. Put the honey extractor in the place designated for that purpose.
2. Attach the honey extractor to the ground, in order to avoid any movements during centrifugation.

2.2. Rules for the use

1. The honey extractor is designed for centrifugation of honey from frames.
2. Before centrifugation, you must thoroughly wash honey extractor in accordance with the guidelines in chapter **Maintenance of the honey extractor**.
3. The arrangement of frames. Place the previously prepared frames in the basket of honey extractor, paying particular attention to their correct position. Honey extractor should be appropriately matched to the type of frames:
 - In the radial honey extractor the top bars of frames should be based on upper and lower the basket rod; if they are too short or too long the honey extractor and frames may be damaged!
 - Frames in both types - we arrange upper bar toward the drum as in **Figure 7**



Fig. 7 The correct arrangement of frames in the Radial basket

4. Before joining to starting the honey extractor, you should:
 - make sure that frames are well placed in the basket of honey extractor, to eliminate the risk of damage (the rules for the use)
 - verify if the safety button is not pressed in
 - then switch on the plug to the socket, and on the control panel, you must switch knob for switching the control, from the position of "0" for "1".
 - Later, you should join to switching the honey extractor, in accordance with the instructions of the honey extractor control – see chapter 5
5. The first phase of the centrifugation should be done slowly, to prevent the possible breaking the honeycombs off. Particular attention should be paid on so-called "young frames".
6. The spinning basket should not be blocked by honey remaining in the drum; if such a situation will occur, you must stop the honey extractor, in order to

prevent its damage. After flowing honey down to containers, you can resume spinning.

7. Containers intended to honey should be place under drain valves.
8. During centrifugation, drain valves should be open, to centrifuged honey could freely flow down.



Attention!!! You can interleave frames only in the moment of total stopping the basket of honey extractor!

3. Honey extractor scheme (diagram)

3.1. PREMIUM LINE electric extractors scheme

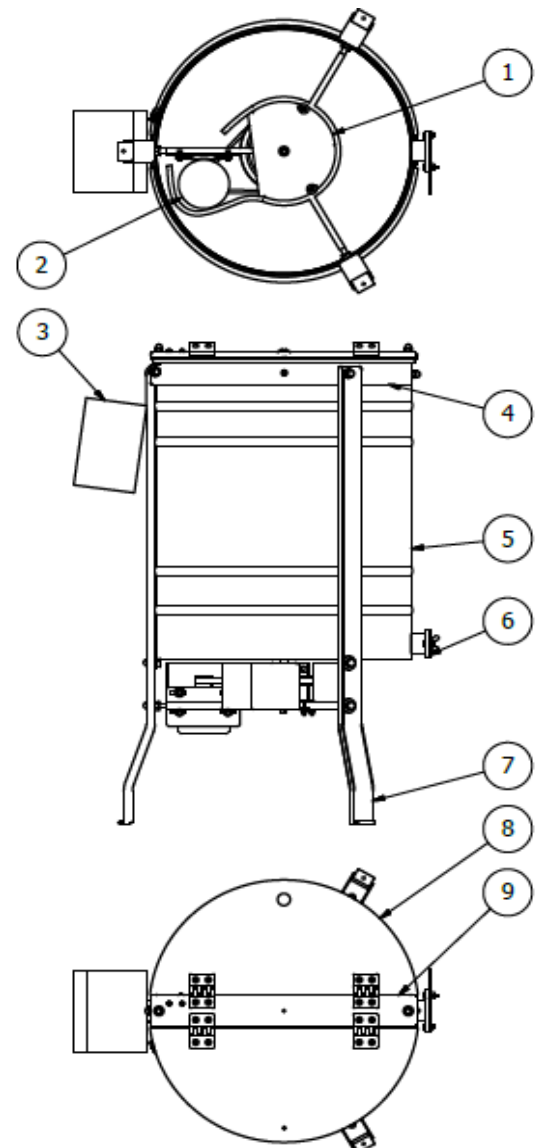

DESCRIPTION

1. Motor protector
2. Motor 350W/24V
3. SDD-3 controller
4. Rim of honey extractor, stainless steel
5. Drum

6. Valve 5/4", stainless steel
7. Legs, long and stainless steel
8. Top cover, stainless steel
9. Fastening strip, stainless steel

3.2. PREMIUM LINE electric+manual extractors scheme

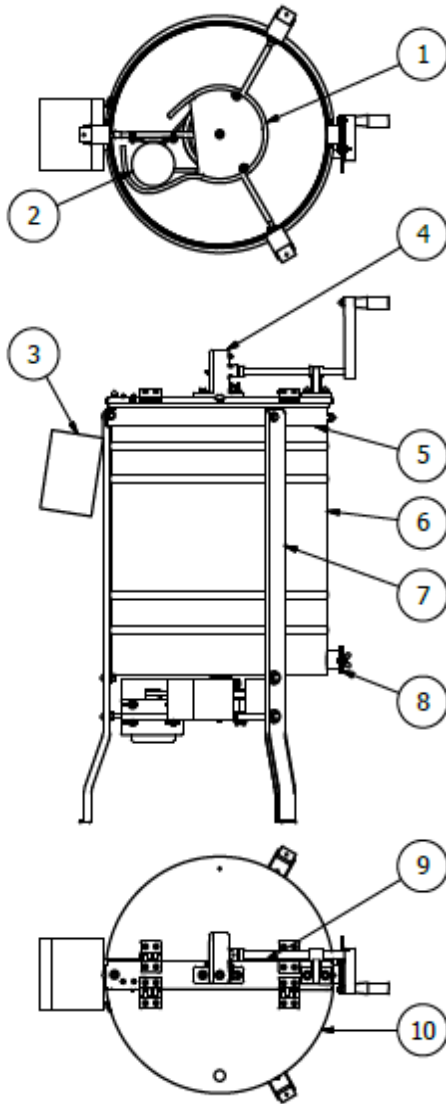

DESCRIPTION

1. Motor protector
2. Motor 350W/24V
3. SDD-3 controller
4. Manual drive
5. Rim of honey extractor, stainless steel
6. Drum
7. Legs, long and stainless steel
8. Valve 5/4", stainless steel
9. Fastening strip, stainless steel
10. Top cover

4. Characteristics of PREMIUM LINE honey extractors

Honey extractors type Premium Line are products made from the highest quality materials and components, which provide the longer service life for products from this line. We want to offer security to our customers for long years. We focus on the development and modern solutions as well as the satisfaction of our customers, therefore, the products of the Premium Line are covered by a five-year warranty.

Honey extractors type PREMIUM have a basket completely made of stainless steel, acid-resistant bars. The hoops of the basket are equipped with laser-cut attachments to prevent falling over frames during centrifugation. The basket has a reinforced structure, is additionally equipped with bearings in two holders- upper and lower.

4.1. Tangential and radial honey extractors

Tangential honey extractors for 3, 4 frames are made of stainless, acid-resistant steel. Extractors are equipped with electric or manual and electric drive

4.2. Technical parameters of tangential and radial honey extractors

- **Drum** made of stainless steel acid-resistant suitably reinforced and stiffened.
- **Side of the a drum** is made of steel with a thickness of 0.8mm, the conical bottom(made of steel with a thickness of 0.6mm) make easier to freely flow down
- **Stand(legs)** made of stainless, acid-resistant steel

Honey extractors with electric drive and with both electric and manual drives are additional reinforced with stiffening cross made of stainless steel.

- **Tangential basket** is made of stainless steel, acid-resistant bars with thickness of 2mm and 5mm. Bottom of a basket is equipped with grips for frames. Basket is mounted in reinforced cross.
- **Mesh size** 10mm x 10mm
- **Honey extractor** is powered by voltage of 230V or 12V
- **Controller** is equipped with few unique solutions, making using more comfortable and economical.
- **In honey extrators applied a belt transmission.** Motor: 350W. Cover of manual drive is made of powder coated metal.

- **Steel gears** transfer torque on axle of basket.
- **Covers**, made of plexiglas(Plexi) with thickness of 5 mm, protect from danger of contact with spinning basket and dirt.
- **Valve 5/4"**, stainless steel.

Tangential honey extractors FI 500 are not suitable for WP frames.

Radial honey extractors FI 600 are designed for WL ½ and Dadant ½ frames.

5. Controller in tangential and radial PREMIUM LINE honey extractors FI 500-600

5.1 Advanced automatic controller SDD-3

Basic features of SDD-3 controller:

- simple and intuitive control panel (buttons: MINUS, PLUS, STOP)
- large and clear graphic display showing: speed index, time of work, voltage, temperature and power provided to motor
- integrated emergency braking loop
- possibility to configure speed and acceleration time precisely
- possibility to choose frequency of modulation precisely
- supports WiFi devices(control with tablet, mobile phone or computer)
- Auto Power OFF function – turn off extractor after set time of inactivity
- control of powering voltage(too high, too low)
- function checking temperature of working controller
- automatic fitted power provided to motor – depended on powering voltage
- advanced diagnostic and error reporting

5.2. User manual of controller in PREMIUM LINE honey extractors



5.3. Configuration of controller

The controller SDD-3 has got extended menu allows fitting characteristics of work and look of interface for individual user's preferences. To start configuration of controller:

- Hold button STOP when honey extractor starts(there is progress bar on a screen) and release the button when you heard sound signal two times.
- PLUS and MINUS allows modifying chosen parameter.
- Choose parameter to modify with STOP.

Using the controller – local panel

After turn on, controller makes a sequence of self-diagnose, after displaying main screen it enters to normal work mode – waiting for motor. On display appears "0" indicates exclusion of rotation. Inclusion of rotation is followed by pressing button with symbol **plus**. First pressing (**from 0 to 1**) begins start procedure. Controller starts from higher power and after time it decrease to chosen level. Next pressing of button **plus** or **minus** causes change speed of rotation. By pressing **minus(to level 0)** or **STOP button** you can turn off rotation.

5.4. List and description of parameters

LOW: 10...40% - increase setting by 1% , default:

The speed of the motor corresponding to the setting speed 1.

HIGH: 70...100% - increase setting by 1% , default:

The speed of the motor corresponding to the setting speed 10.

ACC: 5...300s – increase setting by 5s , default:

The time required to accelerate motor from stop state (D=0%) to full speed of rotation (D=100%).

FREQ.: 1,0 ... 6.0 kHz – increase setting by 0,1kHz, default:

Frequency modulation of motor. Change the frequency modulation allows the elimination of annoying "whistling the motor".

FORCE: 1...5s – increase setting by 1s, default:

Time when starting (pass from 0 to 1) drive pushing the motor with increased filling (increased power) 60%.

BREAK.: 1...5s – increase setting by 1s, default:

Time, after stopped motor, when controller turns off relay permit operation – begins braking with short circuit.

AUTO OFF: 60...900s – increase setting by 30s , default:

Time, counting from last activity, when controller stops rotation of motor itself.

LV ALARM: 9,8 ... 12,5V – increase setting by 0,1V , default:

Threshold value specifies minimum voltage of controller work. Detection of lower voltage will turn extractor off and report alarm.

DISPLAY: P/N , default:

Change mode of screen (positive / negative)

LAYOUT: 1/2/3 , default: ...

View displayed graphic of work mode.

1 – full information

2 – animation of rotating extractor

3 - the maximum size of the displayed speed index

CONTRAST: 5...20 – increase setting by 1, default: 10

Set contrast of screen.

BACKLIGHT: 1...10 – increase setting by 1, default: 10

Set the backlighting of screen.

BUZZER: ON/OFF , default: ON

Turning on or turning off sound signal.

LANGUAGE: EN , default: EN

Choosing the language of control.

EXIT: Press +

Exit from configuration menu – after press button **plus** all settings will save in memory of controller.

LFD: Press (+ -)

Loading factory settings of controller – after pressed both plus and minus buttons, all settings takes default values. It will be saved and configuration will be exited.

5.5. List and description of errors

- **E-100** Damaged processor of controller
- **E-200 Minus button** – after power on controller detect pressed / locked “minus button”
- **E-201 Plus button** - after power on controller detect pressed / locked “plus button”

- **E-202 Stop button** - after power on controller detect pressed / locked “Stop button”
- **E-300 High temperature** – under screen of a controller, temperature is higher than 65
- **E-301 High voltage** – voltage of power in controller exceeded:
 - 19,5V – this state lasted 5 seconds
 - 22V – single measurement
- **E-302 Low voltage** – voltage of power decreased under value of LV ALARM parameter and this state lasted mor than 3 seconds

Every SDD-3 controller contains: microprocessor plate of controller, power supply module, DB9 adapter and dedicated WiFi AP module.

6. Storage of honey extractors

After completion of the honey harvest, the device must be thoroughly cleaned and dried.

Before starting the honey extractor, in the case when it has been moved from the room with the lower temperature to spaces of higher temperature, you should wait until it reaches the ambient temperature. Store in dry rooms at a temperature above 0° C.

Before each new season, you should make an additional technical review, and in the event of fault detection, please contact the service center.

7. Maintenance and cleaning honey extractor

ATTENTION!!!

Device cover to be washed with soapy water at room temperature 25

IMPORTANT!!!

Do not use any detergents with alcohol (causes cracking in plexi glass)

IMPORTANT!

Before starting maintenance, please pull the mains plug.

After completion of the honey harvest, you must thoroughly wash the honey extractor with hot water with a small amount of preparations (authorized for use in the food industry) or using a pressure washer. When washing, you must take special care, in order to prevent moisture of the motor and controller of honey extractor (at the time of washing can be covered by waterproof material).

When washing, you should also take care to prevent flooding the bearings located under the drum; for that purpose, you should shield the hole inside the drum through which passes the axis of the basket. After washing, thoroughly rinse and dry the honey extractor.

Before each season, you should make an additional technical review and in the event of fault detection, please contact the service center.

7.1. Disassembly of the basket in PREMIUM LINE honey extractors

- unscrew the motor protector(scheme 3.1)
- take off the belt from motor(scheme 3.2)
- unscrew the pulley wheel of honey extractor
- unscrew the strip of honey extractor and take it off
- take out the basket

8. Disposal

The Worn out product shall be subject to disposal as waste only in the selective collection of waste organized by Network of Municipal Collection Points for Waste Electrical and Electronic Equipment. The consumer shall have the right to return used equipment in the electrical

equipment distributor network, at least, free of charge and directly if a device that is returned is the proper kind and provides the same functionality as the newly purchased equipment.

9. Warranty

Products purchased in the "Łysoń" company are covered by manufacturer's warranty.

The warranty period is 7 years*

On purchased products shall be issued a receipt or VAT invoice.

*-see our Terms and Condition on our website